

SC-CH4 Stationary Detector of Combustible Gases

 Certificate: ATEX



Measuring of combustible gases 0-100 % LEL
Thermal compensation and linearization of the signal
Displaying of values on the LCD with adjustable lighting.
Controlling by 2 buttons after entering a four-digit code.
Czech, Russian and English in the standard version

Connection to the DKD2000, PNS and other systems by means of a current, voltage and frequency signal or by means of the Modbus protocol to RS485-IS.

Arbitrarily adjustable analogue output, max. 5V, max. 22 mA (e.g. 0.2-1mA, 4-20 mA, 0.4-2V etc.)

Adjustable digital output (galv. separated, PNP, Namur), monitoring of the concentration level, temperature; arbitrary frequency transfer 1-999 Hz (e.g. 5-15 Hz, 200-600 Hz etc.).

Checking of outer and inner voltages, temperature, calibration period, detector age, memory tests, indication of special conditions on the display and on the outputs.

Saving of concentration, temperature, voltage and condition to the memory every minute, periodically for 24 hours.

Use:

The SC-CH4 sensor is intended for continuous measuring of combustible gases volume concentration in the atmosphere within the range of 0 to 5 % of methane in the air or 0 to 100 % of the lower gas explosion limit. The explosion-proof design of I M 1/ii 2 GD Ex ia d I IIC T135°C allows the detector to be used even in the environments with the explosion risk in coal mines or in the zones 1, 2, 21 and 22.

The M version for coal mines (Group I) is equipped with a burn sensor intended for methane measuring, or it allows hydrogen measuring. The sensor has an active carbon filter and it is not intended for measuring of other gases. The sensor has increased resistance to hydrogen (mono)sulphide and silicones.

The C version for chemical industry (Group II) is intended for measuring of methane, ethane, propane, butane, pentane, hexane and it allows to measure carbon monoxide (fatal concentrations of carbon monoxide) and hydrogen, or other combustible gases. The sensor does not allow measuring heavy hydrocarbons, alcohols, ketones, esters and compounds of sulphur. The sensor has increased resistance to hydrogen (mono)sulphide and silicones.

Technical parameters of SC-CH4:

Design	I M1 Ex ia d I II 2GD Ex iaD IIC T135°C
Supply voltage	10-30 V (10-22V, gr. IIC)
Current consumption at 10 V	45 mA (= output current) +5 mA light. + 5 mA comm.
Current consumption at 20 V	28 mA (+ output current) +3 mA light. + 3 mA comm.
Current consumption at 30 V	24 mA (+ output current) +2 mA light. + 2 mA comm.
Voltage analogue output	arbitrary 0.0 – 5.0 V
Current analogue output	arbitrary 0.0 – 22.0 mA
Frequency output	arbitrary 1-999 Hz
Output error	<± 1% of the range
Max. switched voltage of trans. Output	3-30V DC
Max. switched current	0.3A
Max. switched output	3W
Ambient temperature	-20°C - +50°C
Relative humidity	15-95%, non-condensing
Protection	IP54
Dimensions, bushings included	142 x 100 x 75mm

Intrinsic safe parameters:

Ui	30V (I,IIA,II B) 22V (IIC)
Pi	3W (I) 1.25W (II)
Ci	0
Li	200µH
Uo analogue output	7.9V
Io analogue output	80mA
Uo output RS485 (ver. 4)	4.15V
Io output RS485 (ver. 4)	140mA

Measuring parameters

Measuring range	0-5% CH ₄ (0-100% LEL)
Measured gases, gr. I (ver.M)	Methane (or hydrogen)
Measured gases, gr.II (ver. C)	Methane, ethane, propane, butane, pentane, hexane (or CO, H ₂)
Atmospheric pressure	80-120kPa
Max. air speed	6m/s
Max. Dustiness	1g/m ³
Heating time	20 s for measuring 30 m for calibration
Response time T ₅₀	<7s
Response time T ₉₀	<20s
Sensor life time	2-3 years
Calibration curve deviation	<±0.1% CH ₄ or
Short-time instability gr. I	±5 % of the measured value
Calibration curve deviation	<±0,25% CH ₄ or
Short-time instability gr. I	±10 % of the measured val.

The catalogue has only those selected important parameters for your final decision. For project designs always ask for the user's guide for this product and any engineering consultation about possible uses.

SC-CH4 Stationary Sensor of Combustible Gases, SC-LCD Secondary Display Device

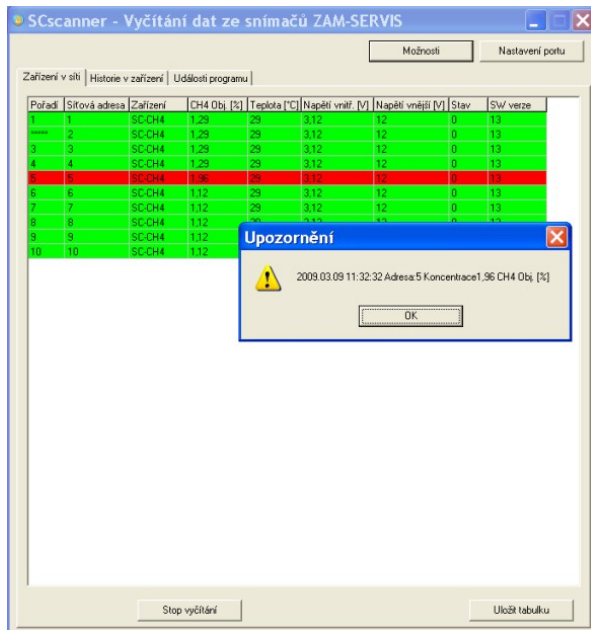
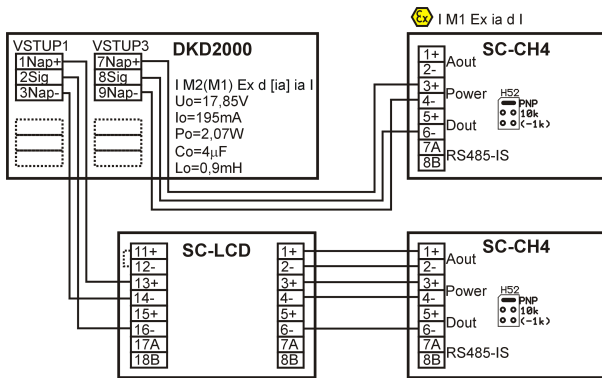

Use of SC-LCD:

The displaying device SC-LCD is intended for displaying of the volume concentration of combustible gases from the connected detector in the range of 0 to 5 % of methane in the air. The fire-proof design of I M 1/II 2GD Ex ia IAD /III C T135°C makes it possible to use it even in the rooms with the SNM explosion in coal mines or in the zones 1, 2, 21 and 22 (21, 22 – coal dust only).

The SC-LCD secondary displaying device is used when the detector is installed in an inaccessible place (for example on the ceiling), i.e. out of the reach of the operation staff. SC-LCD is designed in order all the signals from the sensor go through the display device to the subsequent device.

Technical parameters of SC-LCD:

Design	I M1 Ex ia I II 2GD Ex iaD IIC T135°C
Supply voltage	8-30 V (8-22 V, gr. IIC)
Current consumption	20 mA (+13 mA light.) (+5 mA, if there is communication)
Voltage analogue input	arbitrary 0.0 – 5.0 V
Current analogue input	arbitrary 0.0 – 22.0 mA
Analogue input error	<±1% of the range
Measuring range	0-5% CH4
Ambient temperature	-20°C - +50°C
Relative humidity	max. 95, non-condensing
Protection	IP65
Dimensions, bushings included	170x100x65mm

Intrinsic safe parameters:

U _i	30V (I,IIA, IIB) 22V (IIC)
P _i	3W (I) 1.25W (II)
C _i	0
L _i	10μH
U _o output RS485 (ver. 4)	4.15V
I _o output RS485 (ver. 4)	140mA

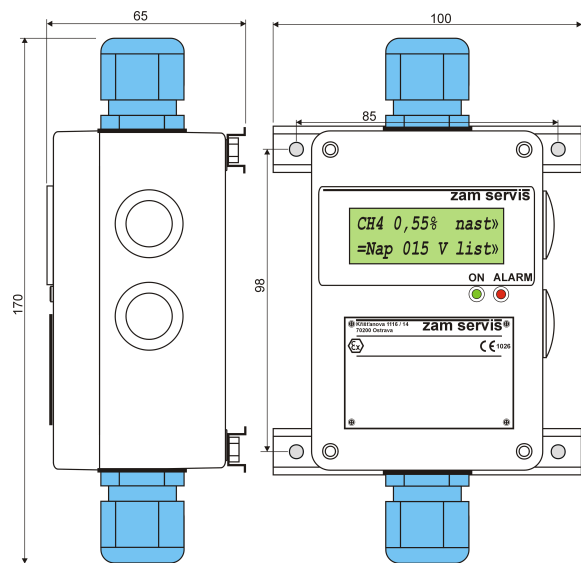
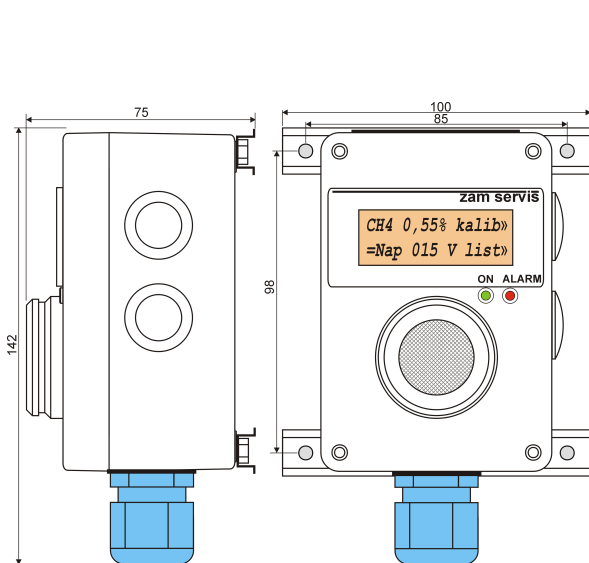

The catalogue has only those selected important parameters for your final decision. For project designs always ask for the user's guide for this product and any engineering consultation about possible uses.